

DOBERMAN

Installation Instructions

The Doberman antennas are high-performance, 5G, CAT18 antennas, available with MIMO LTE, CBRS, Up to 3X WiFi, and GPS. The Doberman Series antennas are perfect for mobile and fixed wireless applications.



OPTIONAL ACCESSORIES

PTA0251 – 1 inch Star Lock Washer

PTA0346 – Heavy Duty Hardware Kit (Nut, Lock Washer and Flat Washer)

PTA0339 – Gasket Adapter for 2020 Charger (Roof Mounting)

PTA0340 – Gasket Adapter for 2020 Explorer (Roof Mounting)

REQUIRED TOOLS

Hammer / Rubber Mallet

Drill and 0.1in Drill Bit

Phillips Screwdriver

1 in Hole Saw

SMA Wrench

Mounting Options

Step 1.

Select a mounting location where there is no obstructions within a radius of 24in. and is easily accessible.

Step 2.

Select one of the mounting options below, depending on your use.

– **Roof Mount (Included)**

Doberman antennas can be mounted on an automobile roof or any flat surface using the hardware provided with it.

– **Magnetic Mount (Optional Part Number: PTA0330)**

For temporary use. Doberman antennas can be mounted on any ferrous metal surface using magnetic mount brackets.

– **Pole Mount (Optional Part Number: PTA0149)**

Antennas can be mounted on a pole with an optional bracket. For more information on mounting, view the pole mount instructions listed on our website.

Roof Mount Instructions

Preparing the Hole

Step 1.

After selecting the location to mount the Antenna, mask the mounting location to avoid paint damage. Mark the hole center with ink or scribed cross hairs.

Step 2.

Use a center punch to make a dimple on the marked location to avoid drill bits from walking across the sheet metal. Use a Twist drill of diameter about 0.1" and drill a pilot hole. Using a 1.0" diameter sheet metal hole saw, drill the hole.

Step 3.

The hole saw will cut the required diameter hole with less risk of stretching and distorting the vehicle surface. Clean up any metal shavings from the hole cutting process. (Figure 1)

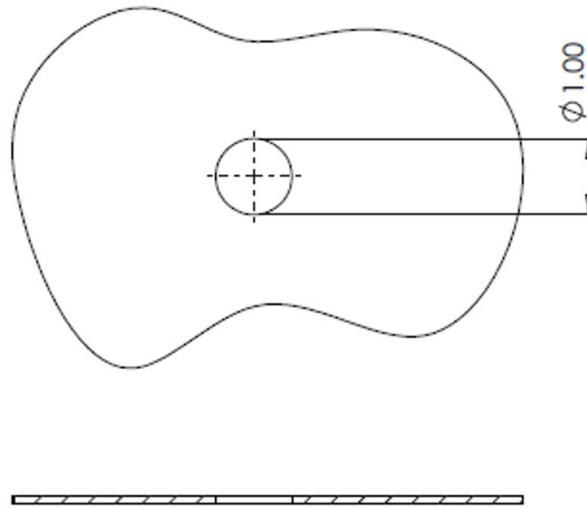

FIGURE 1

Mounting the Antenna

Step 1.

Feed the coaxial cables from the antenna through the hole from the outside surface to the inside surface and thread the entire length of the cable through the hole.

Step 2.

Clean debris off the vehicle surface and then mark the desired antenna orientation by placing the antenna flat on the vehicle surface.

Step 3.

Lift the antenna and remove the protective backing from the underside of the antenna and place the antenna back in the desired position. Apply downward pressure on the antenna to stick it to the panel. This step is optional if you plan on mounting the antenna magnetically.

Step 4.

To avoid the gap between the antenna and panel, it is recommended to use neutral cure silicon sealant around the base of the mounting boot to fully compress the antenna to the mounting panel.

Step 5.

A split flat washer and a split hex nut are provided in the kit for easy installation. (Star washer is optional and not supplied. Part Number: PTA0251)

On the inside of the vehicle, thread the flat washer over the cable, followed by star washer (if applicable) and then hex nut. (Figure 2 & 3)

Slide the washers and nut to the threaded flange of the antenna and tighten the hex nut until antenna compresses flat with the surface of the vehicle. (Figure 4)

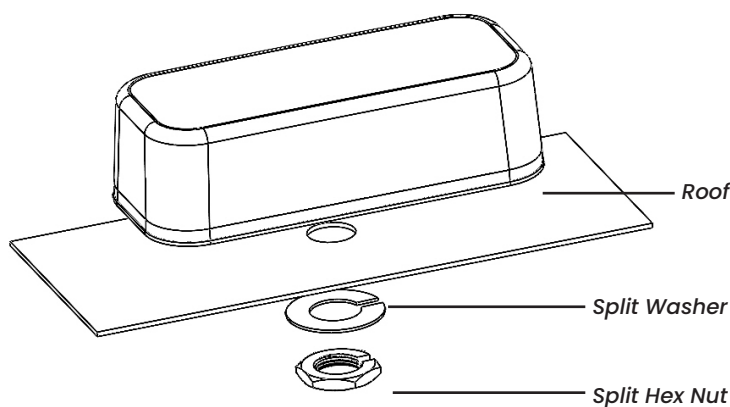

FIGURE 2

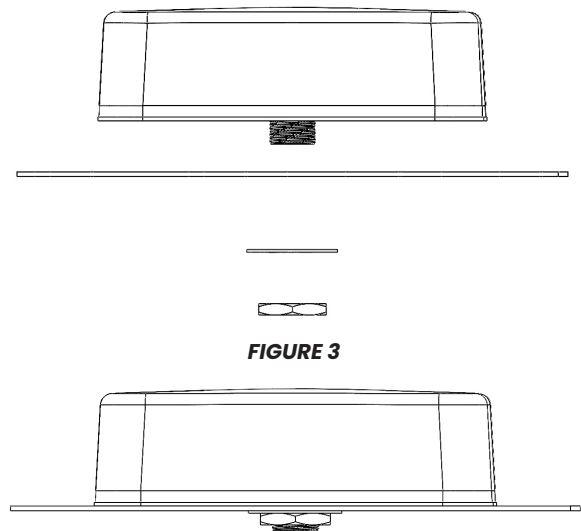

FIGURE 3

FIGURE 4

Routing the Cables

Step 1.

Route the cable from the antenna to the router by maintaining a minimum bend radius of 0.5in. Avoid sharp bends. Run the cables adjacent to existing wiring.

Step 2.

Waterproof the RF connectors using electrical tape or a heat shrink tube, if required.

Magnetic Mount Instructions (PTA0330)

Step 1.

Choose a mounting location. The magnetic mount can be mounted on ferromagnetic metals like iron, steel, nickel etc but not aluminum, copper etc.

Step 2.

Make sure all of the magnets stick firmly to the base. If the surface is a curve adjust the magnets heights using washer.

Step 3.

Make sure the antenna is mounted at least 18 inches or as far as possible from the other roof mounted items like antennas, light bars etc. to avoid any de-tuning or interference issues.

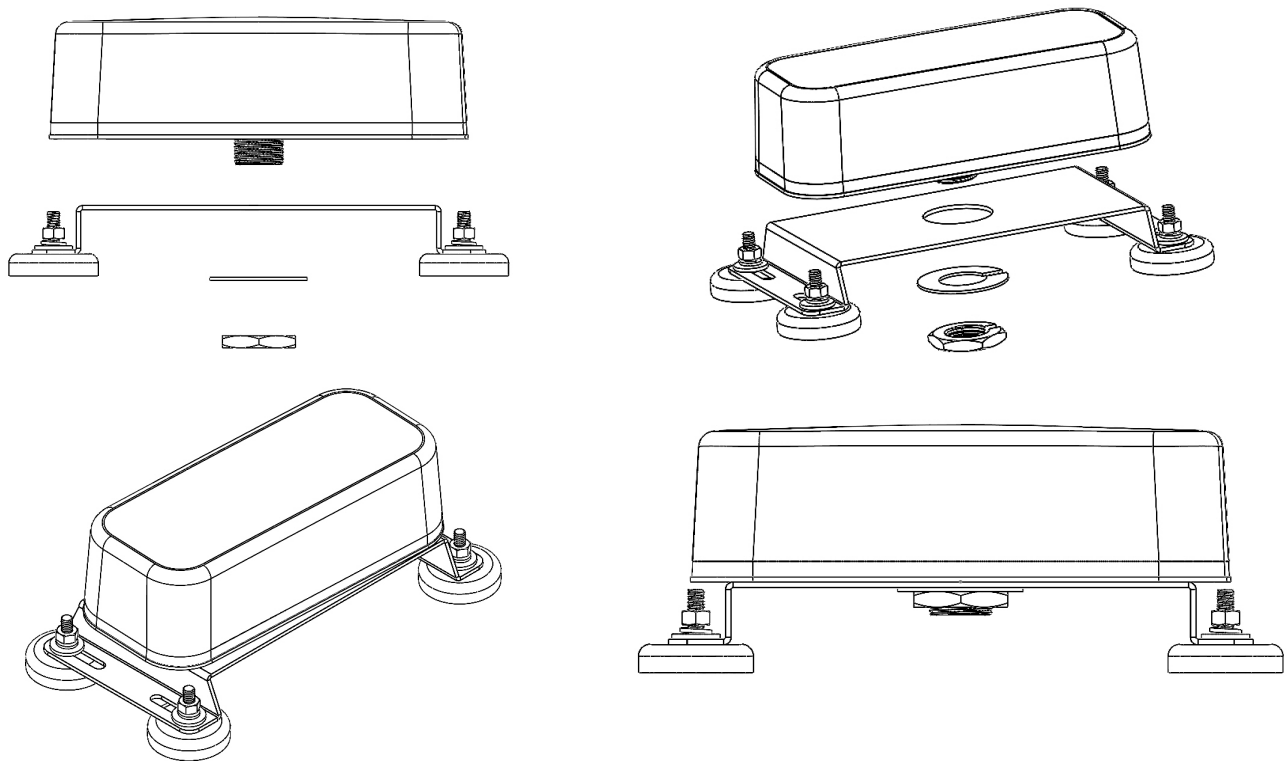

Routing the Cables

Step 1.

Route the cable from the antenna to the router by maintaining a minimum bend radius of 0.5in. Avoid sharp bends. Run the cables adjacent to existing wiring.

Step 2.

Waterproof the RF connectors using electrical tape or a heat shrink tube, if required.

Cable Connection Instructions

Note: SMA connectors have a **maximum** torque of 3-5 inch lbs.

Step 1.

Clean the connector such that there is no dust in the terminals.

Step 2.

Connect the cables from the antenna to the designated connector on the router as shown in the table below.

S.No	CABLE FROM ANTENNA	CONNECTOR ON ROUTER
1	LTE 1	MAIN0
2	LTE 2	AUX0
3	GPS	GPS
4	WIFI 1	2.4/5GHz, LEFT GOLD
5	WIFI 2	2.4/5GHz, RIGHT GOLD
6	WIFI 3	5GHz, LEFT GOLD

For best MIMO performance use the following in pairs:

LTE1 & LTE2

WIFI 1 & WIFI 2

WIFI 3

Commission and Testing

Check Coaxial Cables

Check each coaxial cable connector and confirm it can't be easily unscrewed with two fingers. Visually inspect coaxial cable run for proper mechanical support.





Confirm Connection to Cellular Network

Use a cellular device's built in diagnostics to confirm the RSSI is better than -75dB. Confirm the cellular connection supports communications at required data rates.

Connect the GPS / GNSS cable to the GPS / GNSS receiver and check for satellite acquisition.

Connect the Cellular / LTE & WLAN cables or stow unused pigtails.

Notices:

 <p>CAUTION To comply with FCC RF Exposure requirements in section 1.1310 of the FCC Rules, antennas used with this device must be installed to provide a separation distance of at least 20 cm from all persons to satisfy RF exposure compliance.</p>	 <p>WARNING Watch out for overhead power lines. Check the distance to the power lines before starting installation.</p>
 <p>DO NOT</p> <ul style="list-style-type: none">Operate the transmitter when someone is within 20 cm of the antenna.Install antenna or mast assembly on a windy day	 <p>WARNING This document gives the detailed instructions to install an antenna to the best of our knowledge. This document is for general information only. It cannot be used as a warranty. Parsec Technologies, Inc. will not accept any liability for any damage caused by an antenna due to unknown variables.</p>



Parsec Technologies
972-804-4600
support@parsec-t.com

Last Revised: 3.9.2021