

Greyhound

Installation Instructions



Required Tools & Accessories

Flathead Screwdriver

Phillips Screwdriver

Loctite or 3M Red 271 Threadlocker

Mounting Instructions

Antenna Mounting Location Directions

When selecting the location of an antenna, consider the following factors:

1. **Antenna Directionality** – the direction of the signal is limited by the directionality of the antenna.
Directional antennas focus the coverage on a single direction, usually a 30-to-90-degree cone. This limits connectivity to a particular area but allows for more powerful coverage and a longer signal receiving range than omni-directional antennas. Directional antennas must be pointed towards the signal source.

When selecting the location of a directional antenna, ensure that the antenna can be mounted in such a way that it faces the desired signal source, typically the nearest cell tower.

2. **Signal Path Loss** – signal strength is greatly affected by the materials that the signal passes through.

Severe signal loss can be caused by concrete and brick walls. Metals can absorb and/or reflect the signal, affecting the signal path. **For best antenna performance, select an antenna location with minimal obstructions between the antenna and the signal source(s).**

3. **Reflection & Diffraction** – the signal will bounce off certain materials and bend around obstacles. For best antenna performance, the antenna should be installed in a location where the signal path is not interfered with by materials like Low E glass, Metal, Tinted glass, etc., that reflect RF Energy.

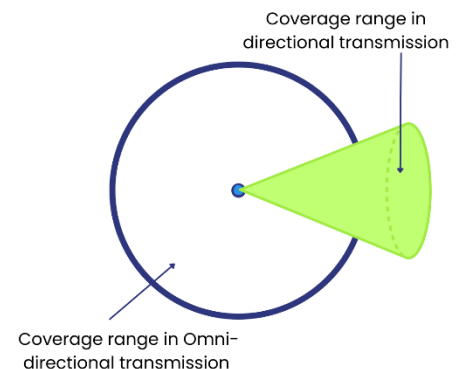

4. Interference – electrical devices and appliances interfere with the antenna’s signal.

Electrical devices and appliances, such as refrigerators, microwaves, AC units, and cameras, can cause electromagnetic interference with the antenna signal.

Select a location that is as far as possible from electrical devices and appliances and minimizes the amount of such devices between the antenna and the signal source(s). For best antenna performance, install antennas as far away as possible from each other and other devices. In general, separate antennas by at least 24 inches (61 cm).

5. Cable Loss – signal strength is lost as RF waves travel through cables.

The longer the cable, the more electrical energy is lost as heat and the higher the signal loss. **Therefore, it is best to select a location for the antenna that allows the cables to be as short as possible and still reach the router.**

The size of the cable also affects cable loss; coaxial cables with higher center conductor diameters have less cable loss compared to thinner coaxial cables.

It is critical to avoid bending coaxial cables sharply to avoid shearing of the Aluminum foil shield, which can result in a significant or complete loss of antenna functionality.

Coaxial cables should not be bent sharply; they have a minimum bend radius which varies depending on the size of cable.

Low-E Windows and Wireless Signal Inside LEED-Certified Buildings

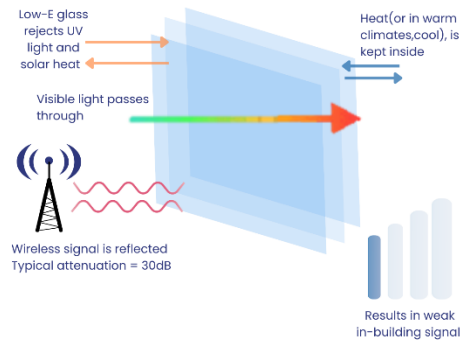

Hardware Accessories

<i>Accessory</i>	<i>Part Number</i>
Pole Mount Kit	PTA0532
Lightning Arrestor – SMA(F) to SMA(F)	PTA0476
Lightning Arrestor – N(F) to N(M)	PTA0736
SMA Wrench, Key Chain	PTA0194
Service: Cable Sleeving (Priced Per Ft)	Cable Sleeving

***Lightning Arrestors are recommended for outdoor installations**

Pole Mount

1. Select the mounting location.
 - A. To avoid de-tuning or interference issues, install the antenna as far away as possible from other devices (minimum 24 inches), including lights, AC units, routers, and other antennas.
 - B. The antenna will need to be pointed towards the nearest cellular tower. A clear line of sight is recommended for best performance.
 - C. The diameter of the pole must be between 2.5 inches - 3.5 inches and the pole must be vertical.
2. Install the two pole mount brackets onto the back of the antenna using the four $\frac{3}{4}$ " screws provided in the kit. Use the Loctite or red thread locker on the screw threads prior to screwing into the back of the antenna.
3. Guide the provided hose clamps through the slots in the pole mount brackets and around the pole, as shown below. Tighten the hose clamps around the pole.
4. Connect the cables from the cable kit to the antenna cables. Make sure to match the cables according to the labels on the antenna cables and the cable kit.
5. Secure the antenna cables to the pole roughly 6 inches below the antenna to provide strain relief. Vinyl electrical tape or cable-ties can be used. If using cable-ties outside, make sure to use UV resistant cable-ties.
 - A. **Ensure that the cables do not bend sharply. Do not bend the cables with a radius of 1.5" or less.**
 - B. Route the antenna cables adjacent to existing wiring as much as possible.

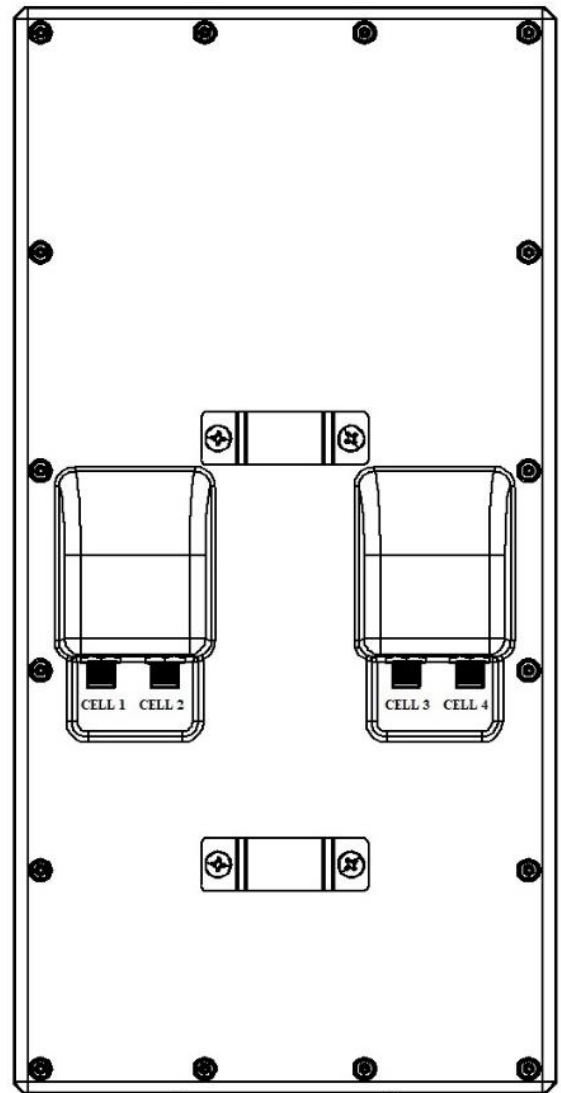

2.5 to 3.5 INCH DIA MAST

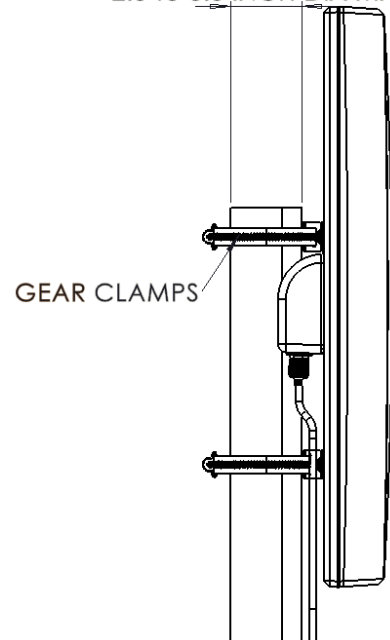

Routing the Cable

1. Properly route the cables, making sure there are no sharp bends. Clamp the cables to the wall at about 6 inches away from the antenna if the cables are being hung straight from the wall.
2. Make sure the antenna is mounted in the correct direction and tighten the mounting hardware. Waterproof the RF connectors using electrical tape, or a heat shrink tube.

Cable Connection Instructions

Step 1:

Use canned air and/or isopropyl alcohol to clean all the connectors to ensure that there is no dust in the terminals.

Step 2.

Connect the antenna cables to the designated terminals on the router, as shown in the tables and images below

One Router

S. No	Cable from Antenna	Connector on Router
1	CELL 1	MAIN0
2	CELL 2	AUX0
3	CELL 3	MAIN1
4	CELL 4	AUX1

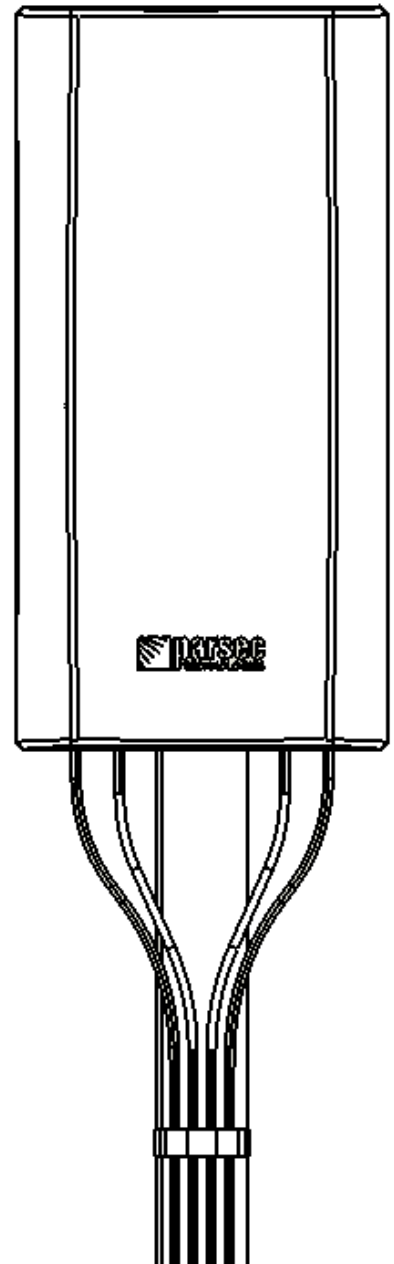

Commission and Testing

Check each coaxial cable connector and confirm that it cannot be easily loosened. Visually inspect the coaxial cables to ensure that they are not sharply bent and are sufficiently secured and supported between the antenna and the router.

Use a cellular device's built-in diagnostics to confirm the RSSI is higher than -75dB. Confirm the cellular connection supports communications at required data rates.

Connect the cellular/LTE cables to the router and stow any unused coaxial cables to avoid damage.



CAUTION

To comply with FOC RF Exposure requirements in section 1.1310 of the FCC Rules, antennas used with this device must be installed to provide a separation distance of at least 20 cm from all persons to satisfy RF exposure compliance.



DO NOT

- Operate the transmitter when someone is within 24 inches of the antenna
- Install the antenna or mast assembly on a windy day
- Install the mast close to power lines as it can cause serious injuries or death



WARNING

Watch out for overhead power lines. Check the distance to power lines before beginning installation.



WARNING

This document gives the detailed instructions to install an antenna to the best of our knowledge. This document is for general information only. It cannot be used as a warranty. Parsec Technologies Inc. will not accept any liability for any damage caused by an antenna due to unknown variables.



Last Revised: 08.07.2023