



St. Bernard Pro Series

A High-Performance 5G Mobile Hot Spot Solution
for Portable Performance



St. Bernard Pro Series



Purpose-Built for Reliable Wireless Communications.



The St. Bernard PRO Series Mobile 5G Hot Spot Case is engineered to deliver dependable wireless connectivity in a **portable, rugged** platform. Optimized for **low-to mid-band** frequencies this device improvea signal reach and reliability. Designed for **immediate** deployment, it combines **advanced 5G** cellular and Wi-Fi technology with a **high-performance** antenna system to provide strong, **consistent coverage** in demanding environments.

Antenna built seamlessly into
Case Lid

Reliable Wireless Coverage On Demand.
Connected Anywhere.

- 4x4 MIMO Cellular
- 4X4 MIMO Wi-Fi
- Omni-Directional
- Failover-Ready With Dual SIM Capability
- IP67 Rated
- Optional GPS



Purpose-Built for Reliable Wireless Communications.

Portable Rugged Design

Optimized for signal strength and efficiency.

The St. Bernard PRO Series is housed in a durable, **impact-resistant** case built to withstand harsh conditions while remaining compact and easy to transport. This **IP67-rated** mobile hotspot solution makes it capable of delivering immediate, dependable wireless coverage in critical environments. Designed for long-term field use, the case incorporates a **built-in fan and ventilation system** to help maintain optimal operating temperatures and features a field-serviceable design that simplifies maintenance and reduces downtime in critical deployments.

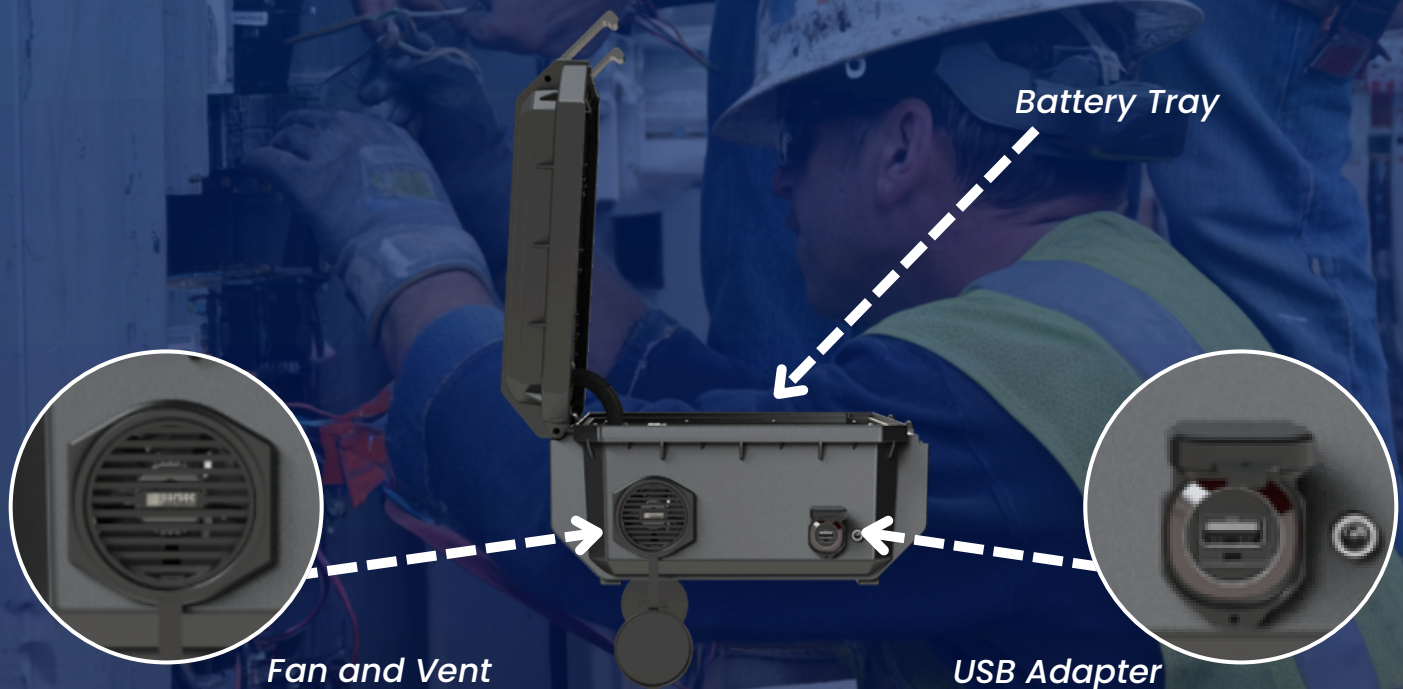

- Durable Shock-Resistant Mobile Case
- On-the-Go Network Solution
- Up to Four RJ45 Panel Mounts

Purpose-Built for Reliable Wireless Communications.

Ready for the Field

Built for mobility and durability.

At the core of the St. Bernard PRO Series is a **high-efficiency** antenna system designed to deliver **exceptional reception** and **transmission performance**. The antenna is seamlessly integrated into the case lid, creating a streamlined, protected solution that maintains optimal performance without external components. Its **omni-directional** architecture further enables reliable coverage in dynamic deployment scenarios, eliminating the need for manual antenna alignment.

- High Isolation and Built-In Ground Plane
- Rugged High-Efficiency, High-Gain Antenna
- 600 MHz–6000 MHz Antenna



Reliability in Every Environment

Applications



Critical Responders



Transportation / Fleet



Education Buildings



Government Buildings



Remote Surveillance



Primary & Failover Network

Why Choose the St. Bernard

- Omni-Directional
- Failover-Ready With Dual SIM Capability
- IP67 Rated
- On-the-Go Network Solution



Specification Overview

PRO St. Bernard Series		
Applications:	Emergency Communication, Backup Mobile Command Center	
Configurations:	9:1 – 4 CELL, 4 Wi-Fi, GPS	
Categories:	Enterprise, Mobile, Public Safety, 5G	
Antennas Included:	Cellular, Wi-Fi, Bluetooth and GPS	
Type:	Case/Enclosure	
Antenna Pattern:	Omni-Directional	
Available Colors:	Black	
Cable Type:	Cellular	RG-316
	Wi-Fi	RG-316
	GPS	LSR100
Standard Cable Length:	18 IN Pigtails	
Standard Connector options:	Cellular	SMA(M)
	Wi-Fi	RP-SMA(M)
	GPS	SMA(M)

Specifications

Frequencies			
4G/5G Cellular	617-894 MHz 1710-2700 MHz 3300-4000 MHz 5150-5925 MHz	Wi-Fi	2400-2483.5 MHz 4900-5900 MHz
		GPS	1575.42 MHz
4G/5G Bands			
North America		B2, B4, B5, B7, B12, B13, B14, B17, B25, B26, B29, B30, B41, B46, B48, B66, B71, n2, n5, n12, n25, n26, n41, n48, n66, n71, n77	
EMEA		B1, B3, B7, B20, B28, B42, B43, B46, n1, n3, n28, n77, n78	
Mechanical		Environmental	
Dimensions	15.04 inch x 12.32 inch x 6.98 inch	Operating Temperature	-30 °C to 85°C OR -22 °F to 180°F
Power	110-120 Volt AC (60 Hz)	Ingress Protection	IP67 for -A Version *when closed IP54 for -G2B, & L Version *when all ports and lid are closed
Battery (not included)	Omnicharge 30C+ OP3CPA01 Custom Battery (-G2 Version)		
Battery (included)	OmniCharge 30C+ OP3CPA01 Custom Battery (-G2B Version)		
Connectors	CELL: SMA (M) Wi-Fi: RP-SMA (M) GPS: SMA (M)	Radome Material	Plastic
Router Options	Ericsson IBR1700 - 1200M Peplink MAX Transit Duo	RF Cable Length	18 inch pigtailed
		Max Router Configuration	4 Cellular, 4 Wi-Fi, GPS
		Max Router Dimensions	8.8" X 7.5" X 1.7"
<ul style="list-style-type: none"> For customizations, such as Connector Type, Cable Length, Color, Configuration, and Branding, please reach out to Parsec at sales@parsec-t.com. For different router configurations, reach out to Parsec for more information. Temperature range is for antenna only. Equipment installed inside the enclosure may have a different temperature range. <p>*Openings in the enclosure for options like fans and power cords may reduce ingress protection even with covers installed.</p>			

Technical Drawing

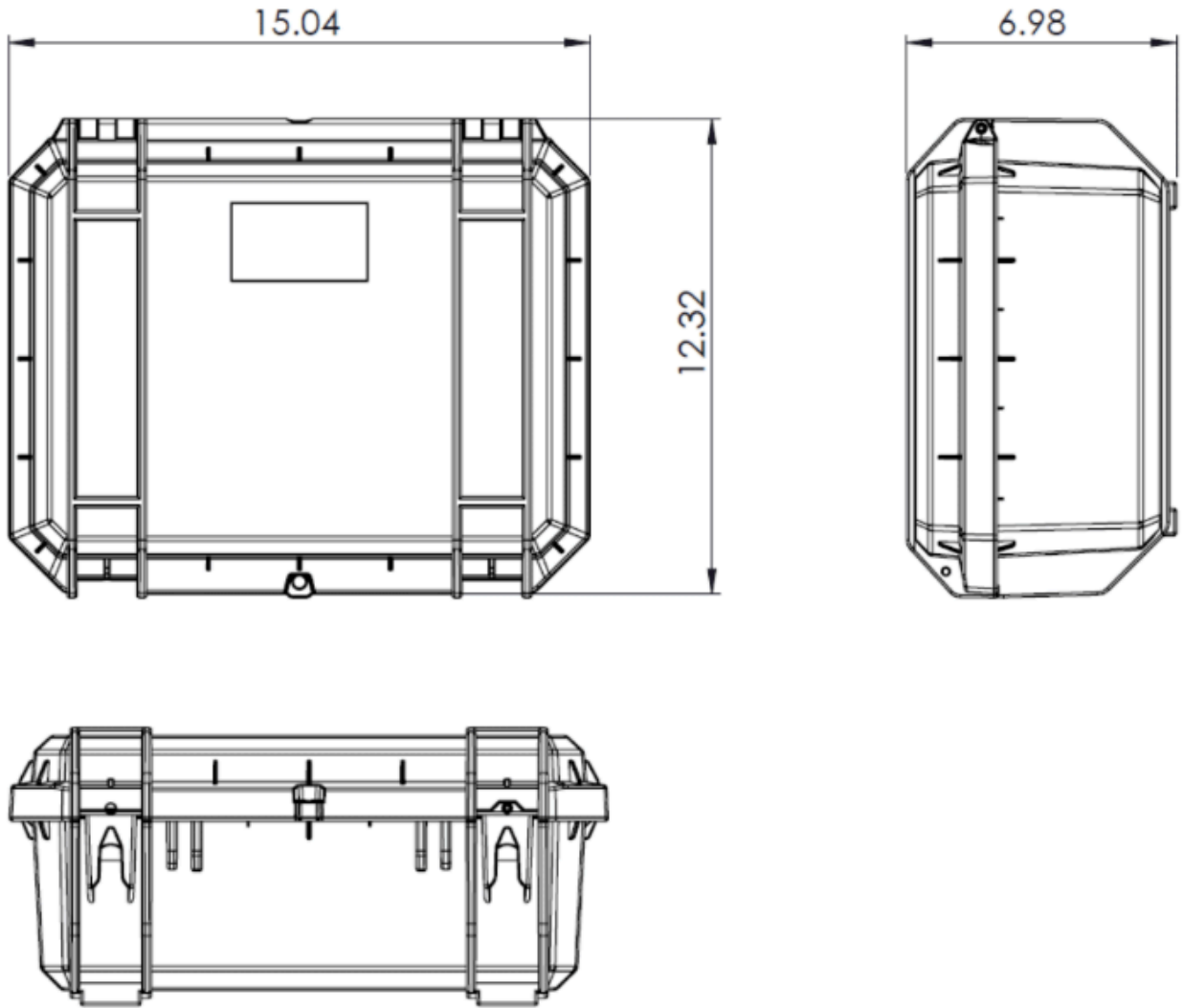

Figure 1: St. Bernard Blueprint

Part Number Key & Ordering Guide

(Part number example for a 9:1 St. Bernard antenna: PRO9SB4L4WG)

<i>Description</i>	<i>Abbreviation</i>	<i>Part Number</i>
All PRO Series	PRO	PRO
Number of Antenna in Housing/Configuration	9:1	PRO9
Antenna Abbreviation for St. Bernard	SB	PRO9SB
Number of Cellular Elements	#L	PRO9SB4L
Number of Wi-Fi Elements	#W	PRO9SB4L4W
Number of GPS Elements	G	PRO9SB4L4WG
Optional L Version - Includes the options listed	-L	PRO9SB4L4WG-L

For customizations, such as Connector Type, Cable Length, Configuration, and Branding, please reach out to Parsec at sales@parsec-t.com.
MOQ Applicable.

Maximum Configurations

<i>Configurations</i>	<i>Part Number</i>	<i>Description</i>
9:1	PRO9SB4L4WG	4 Cellular, 4 Wi-Fi, GPS, Black Case with Antenna Build into Lid
	PRO9SB4L4WG-L	4 Cellular, 4 Wi-Fi, GPS, Black Case with Antenna Build into Lid with AC Adapter (see antenna options for description)
	PRO9SB4L4WG-G2B	4 Cellular, 4 Wi-Fi, GPS, Black Case with Antenna Build into Lid with 30K Battery (see antenna options for description)

<i>Description</i>	<i>PRO9SB4L4WG</i>	<i>-A Version</i>	<i>-L Version</i>	<i>-G2B Version</i>
Antenna	Yes	Yes	Yes	Yes
Fan and Vent	No	No	Yes	Yes
AC Adapter	No	Yes	Yes	No
USB-C Connector	No	No	No	Yes
USB-A Connector	No	No	No	Yes
4x RJ-45 Connectors	No	No	Yes	Yes
Router Mount Plate	No	Yes	Yes	Yes
Top Cover Plate	No	Yes	Yes	Yes
30C+ Battery Tray	No	No	No	Yes
OmniCharge 30C + Custom Battery	No	No	No	Yes
<p>Battery: -G2 Version: Omnicheck 30C+ OP3CPA01 Custom Battery (Batteries are not included with the Antenna and must be purchased separately.) Omnicheck 30C+ OP3CPA01 Custom Battery and charger are included with the -G2B Version. For more information, see our installation instructions at Parsec-t.com for Bernese Mountain Dog Case Series.</p>				

Hardware Accessories

Accessories	Part Number
RJ-45 Adapter	PTA0920
USB-A Panel Mount	PTA0921
USB-C Connector	PTA0633
Replacement Parts	
Omnicharge 30C+CustomBattery (OP3CPA01)	PTA1181
OmniCharge 65W Charger	PTA0746
Top Cover Plate Mounting Screws	PTA0071B
Router Mounting Screws	PTA0399-TL
40mm Fan Replacement Kit (Includes screws and nuts)	PTA0764
40mm Vent and Cap Kit	PTA0477
SMA Wrench, Key Chain	PTA0194
Service: Router Installation	PTA-Install-185

Electrical Specifications

<i>ID</i>	<i>Port</i>	<i>Parameters</i>	<i>Typ.</i>
Radiated Efficiency (%)	CELL 1 thru 4	617-698 MHz	70
	CELL 1 thru 4	698-984 MHz	85
	CELL 1 thru 4	1710-2200 MHz	85
	CELL 1 thru 4	2200-2700 MHz	70
	CELL 1 thru 4	3400-4000 MHz	50
	CELL 1 thru 4	5150-5925 MHz	40
	GPS	1575.42 MHz	80
	Wi-Fi 1 thru 4	2400-2483.5 MHz	80
	Wi-Fi 1 thru 4	4900-5900 MHz	70
Peak Gain (dBi)	CELL 1 thru 4	617-698 MHz	1.5
	CELL 1 thru 4	698-894 MHz	2
	CELL 1 thru 4	1710-2200 MHz	5
	CELL 1 thru 4	2200-2700 MHz	5
	CELL 1 thru 4	3400-4000 MHz	4
	CELL 1 thru 4	5150-5925 MHz	6
	GPS	1575.42 MHz	6
	Wi-Fi 1 thru 4	2400-2483.5 MHz	4
	Wi-Fi 1 thru 4	4900-5900 MHz	6
Return Loss 50 Ω (dB)	CELL 1 thru 4	617-698 MHz	6
	CELL 1 thru 4	698-894 MHz	9
	CELL 1 thru 4	1710-2200 MHz	11
	CELL 1 thru 4	2200-2700 MHz	7
	CELL 1 thru 4	3400-4000 MHz	4
	CELL 1 thru 4	5150-5925 MHz	4
	GPS	1575.42 MHz	12
	Wi-Fi 1 thru 4	2400-2483.5 MHz	14
	Wi-Fi 1 thru 4	4900-5900 MHz	10
Isolation (dB)	CELL	617-894 MHz	12
	CELL	1710-2700 MHz	20
	CELL	3400-4000 MHz	25
	CELL	5150-5925 MHz	35
	Wi-Fi	2400-2483.5 MHz	19
	Wi-Fi	4900-5900 MHz	25

Polarization (dBi)	CELL, Wi-Fi		Linear
Max Input Power (Watts)	CELL, Wi-Fi		10
RF Connectors	CELL Wi-Fi		SMA(M) RP-SMA(M)
RF Cable Type	CELL, Wi-Fi		RG-316

- Isolation, return loss, and peak gain includes cable loss from 18 IN Cables supplied.
- SMA connectors have a max torque of 3-5-inchlbs.
- Electrical specifications based on antenna mounted in the lid of the plastic enclosure.
- ***Router and SIM Card are not included.** Customers should contact Parsec's authorized distributors and VAR's listed on our website for a full list of routers and other options that will complete the Emergency Hot Spot.
- Please see Ordering Guide regarding Battery Inclusion.

GNSS Electrical Specifications

<i>ID & Unit</i>	<i>Port</i>	<i>Parameters</i>	<i>Typ.</i>
Antenna + Preamp Gain (dBic)	GPS	1570-1581 MHz	28
Polarization	GPS		RHCP
Filter Rejection (dB)	GPS	1625 MHz	12
GNSS Preamp Voltage (mA)	GPS		2.2 to 5
GNSS Preamp Current (mA)	GPS		5 to 15
RF Connector	GPS		SMA (M)
RF Cable Type	GPS		LSR100